

2012-2016 ELEMENT 4 EXTRA CLASS QUESTION POOL
As Modified January 30, 2012 to be Effective July 1, 2012 - June 30, 2016

E1A01 [97.301, 97.305] When using a transceiver that displays the carrier frequency of phone signals, which of the following displayed frequencies represents the highest frequency at which a properly adjusted USB emission will be totally within the band?

3 kHz below the upper band edge

E1A02 [97.301, 97.305] When using a transceiver that displays the carrier frequency of phone signals, which of the following displayed frequencies represents the lowest frequency at which a properly adjusted LSB emission will be totally within the band?

3 kHz above the lower band edge

E1A03 [97.301, 97.305] With your transceiver displaying the carrier frequency of phone signals, you hear a DX station's CQ on 14.349 MHz USB. Is it legal to return the call using upper sideband on the same frequency?

No, my sidebands will extend beyond the band edge

E1A04 [97.301, 97.305] With your transceiver displaying the carrier frequency of phone signals, you hear a DX station calling CQ on 3.601 MHz LSB. Is it legal to return the call using lower sideband on the same frequency?

No, my sidebands will extend beyond the edge of the phone band segment

E1A05 [97.313] What is the maximum power output permitted on the 60 meter band?

100 watts PEP effective radiated power relative to the gain of a half-wave dipole

E1A06 [97.303] Which of the following describes the rules for operation on the 60 meter band?

Operation is restricted to specific emission types and specific channels

E1A07 [97.303] What is the only amateur band where transmission on specific channels rather than a range of frequencies is permitted?

60 meter band

E1A08 [97.219] If a station in a message forwarding system inadvertently forwards a message that is in violation of FCC rules, who is primarily accountable for the rules violation?

The control operator of the originating station

E1A09 [97.219] What is the first action you should take if your digital message forwarding station inadvertently forwards a communication that violates FCC rules?

Discontinue forwarding the communication as soon as you become aware of it

E1A10 [97.11] If an amateur station is installed aboard a ship or aircraft, what condition must be met before the station is operated?

Its operation must be approved by the master of the ship or the pilot in command of the aircraft

E1A11 [97.5] What authorization or licensing is required when operating an amateur station aboard

Any FCC-issued amateur license or a reciprocal permit for an alien amateur licensee

E1A12 [97.301, 97.305] With your transceiver displaying the carrier frequency of CW signals, you hear a DX station's CQ on 3.500 MHz. Is it legal to return the call using CW on the same frequency?

No, sidebands from the CW signal will be out of the band.

E1A13 [97.5] Who must be in physical control of the station apparatus of an amateur station aboard any vessel or craft that is documented or registered in the United States?

Any person holding an FCC-issued amateur license or who is authorized for alien reciprocal operation

E1B01 [97.3] Which of the following constitutes a spurious emission?

An emission outside its necessary bandwidth that can be reduced or eliminated without affecting the information transmitted

E1B02 [97.13] Which of the following factors might cause the physical location of an amateur station apparatus or antenna structure to be restricted?

The location is of environmental importance or significant in American history, architecture, or culture

E1B03 [97.13] Within what distance must an amateur station protect an FCC monitoring facility from harmful interference?

1 mile

E1B04 [97.13, 1.1305-1.1319] What must be done before placing an amateur station within an officially designated wilderness area or wildlife preserve, or an area listed in the National Register of Historical Places?

An Environmental Assessment must be submitted to the FCC

E1B05 [97.303] What is the maximum bandwidth for a data emission on 60 meters?

2.8 kHz

E1B06 [97.15] Which of the following additional rules apply if you are installing an amateur station antenna at a site at or near a public use airport?

You may have to notify the Federal Aviation Administration and register it with the FCC as required by Part 17 of FCC rules

E1B07 [97.15] Where must the carrier frequency of a CW signal be set to comply with FCC rules for 60 meter operation?

At the center frequency of the channel

E1B08 [97.121] What limitations may the FCC place on an amateur station if its signal causes interference to domestic broadcast reception, assuming that the receiver(s) involved are of good engineering design?

The amateur station must avoid transmitting during certain hours on frequencies that cause the interference

E1B09 [97.407] Which amateur stations may be operated in RACES?

Any FCC-licensed amateur station certified by the responsible civil defense organization for the area served

E1B10 [97.407] What frequencies are authorized to an amateur station participating in RACES?

All amateur service frequencies authorized to the control operator

E1B11 [97.307] What is the permitted mean power of any spurious emission relative to the mean power of the fundamental emission from a station transmitter or external RF amplifier installed after January 1, 2003, and transmitting on a frequency below 30 MHz?

At least 43 dB below

E1B12 [97.307] What is the highest modulation index permitted at the highest modulation frequency for angle modulation?

1.0

E1C01 [97.3] What is a remotely controlled station?

A station controlled indirectly through a control link

E1C02 [97.3, 97.109] What is meant by automatic control of a station?

The use of devices and procedures for control so that the control operator does not have to be present at a control point

E1C03 [97.3, 97.109] How do the control operator responsibilities of a station under automatic control differ from one under local control?

Under automatic control the control operator is not required to be present at the control point

E1C04 [97.109] When may an automatically controlled station retransmit third party communications?

Only when transmitting RTTY or data emissions

E1C05 [97.109] When may an automatically controlled station originate third party communications?

Never

E1C06 [97.109] Which of the following statements concerning remotely controlled amateur stations is true?

A control operator must be present at the control point

E1C07 [97.3] What is meant by local control?

Direct manipulation of the transmitter by a control operator

E1C08 [97.213] What is the maximum permissible duration of a remotely controlled station's transmissions if its control link malfunctions?

3 minutes

E1C09 [97.205] Which of these frequencies are available for an automatically controlled repeater operating below 30 MHz?

29.500 - 29.700 MHz

E1C10 [97.113] What types of amateur stations may automatically retransmit the radio signals of other amateur stations?

Only auxiliary, repeater or space stations

E1D01 [97.3] What is the definition of the term telemetry?

One-way transmission of measurements at a distance from the measuring instrument

E1D02 [97.3] What is the amateur satellite service?

A radio communications service using amateur radio stations on satellites

E1D03 [97.3] What is a telecommand station in the amateur satellite service?

An amateur station that transmits communications to initiate, modify or terminate functions of a space station

E1D04 [97.3] What is an Earth station in the amateur satellite service?

An amateur station within 50 km of the Earth's surface intended for communications with amateur stations by means of objects in space

E1D05 [97.207] What class of licensee is authorized to be the control operator of a space station?

All classes

E1D06 [97.207] Which of the following special provisions must a space station incorporate in order to comply with space station requirements?

The space station must be capable of terminating transmissions by telecommand when directed by the FCC

E1D07 [97.207] Which amateur service HF bands have frequencies authorized to space stations?

Only 40m, 20m, 17m, 15m, 12m and 10m

E1D08 [97.207] Which VHF amateur service bands have frequencies available for space stations?

2 meters

E1D09 [97.207] Which amateur service UHF bands have frequencies available for a space station?

70 cm, 23 cm, 13 cm

E1D10 [97.211] Which amateur stations are eligible to be telecommand stations?

Any amateur station so designated by the space station licensee, subject to the privileges of the class of operator license held by the control operator

E1D11 [97.209] Which amateur stations are eligible to operate as Earth stations?

Any amateur station, subject to the privileges of the class of operator license held by the control operator

E1E01 [97.509] What is the minimum number of qualified VEs required to administer an Element 4 amateur operator license examination?

3

E1E02 [97.523] Where are the questions for all written US amateur license examinations listed?

In a question pool maintained by all the VECs

E1E03 [97.521] What is a Volunteer Examiner Coordinator?

An organization that has entered into an agreement with the FCC to coordinate amateur operator license examinations

E1E04 [97.509, 97.525] Which of the following best describes the Volunteer Examiner accreditation process?

The procedure by which a VEC confirms that the VE applicant meets FCC requirements to serve as an examiner

E1E05 [97.503] What is the minimum passing score on amateur operator license examinations?

Minimum passing score of 74%

E1E06 [97.509] Who is responsible for the proper conduct and necessary supervision during an amateur operator license examination session?

Each administering VE

E1E07 [97.509] What should a VE do if a candidate fails to comply with the examiner's instructions during an amateur operator license examination?

Immediately terminate the candidate's examination

E1E08 [97.509] To which of the following examinees may a VE not administer an examination?

Relatives of the VE as listed in the FCC rules

E1E09 [97.509] What may be the penalty for a VE who fraudulently administers or certifies an examination?

Revocation of the VE's amateur station license grant and the suspension of the VE's amateur operator license grant

E1E10 [97.509] What must the administering VEs do after the administration of a successful examination for an amateur operator license?

They must submit the application document to the coordinating VEC according to the coordinating VEC instructions

E1E11 [97.509] What must the VE team do if an examinee scores a passing grade on all examination elements needed for an upgrade or new license?

Three VEs must certify that the examinee is qualified for the license grant and that they have complied with the administering VE requirements

E1E12 [97.509] What must the VE team do with the application form if the examinee does not pass the exam?

Return the application document to the examinee

E1E13 [97.519] What are the consequences of failing to appear for re-administration of an examination when so directed by the FCC?

The licensee's license will be cancelled

E1E14 [97.527] For which types of out-of-pocket expenses do the Part 97 rules state that VEs and VECs may be reimbursed?

Preparing, processing, administering and coordinating an examination for an amateur radio license

E1F01 [97.305] On what frequencies are spread spectrum transmissions permitted?

Only on amateur frequencies above 222 MHz

E1F02 [97.5] Which of the following operating arrangements allows an FCC-licensed US citizen to operate in many European countries, and alien amateurs from many European countries to operate in the US?

CEPT agreement

E1F03 [97.315] Under what circumstances may a dealer sell an external RF power amplifier capable of operation below 144 MHz if it has not been granted FCC certification?

It was purchased in used condition from an amateur operator and is sold to another amateur operator for use at that operator's station

E1F04 [97.3] Which of the following geographic descriptions approximately describes "Line A"?

A line roughly parallel to and south of the US-Canadian border

E1F05 [97.303] Amateur stations may not transmit in which of the following frequency segments if they are located in the contiguous 48 states and north of Line A?

420 - 430 MHz

E1F06 [97.3] What is the National Radio Quiet Zone?

An area surrounding the National Radio Astronomy Observatory

E1F07 [97.113] When may an amateur station send a message to a business?

When neither the amateur nor his or her employer has a pecuniary interest in the communications

E1F08 [97.113] Which of the following types of amateur station communications are prohibited?

Communications transmitted for hire or material compensation, except as otherwise provided in the rules

E1F09 [97.311] Which of the following conditions apply when transmitting spread spectrum emission?

All of these choices are correct

E1F10 [97.313] What is the maximum transmitter power for an amateur station transmitting spread spectrum communications?

10 W

E1F11 [97.317] Which of the following best describes one of the standards that must be met by an external RF power amplifier if it is to qualify for a grant of FCC certification?

It must satisfy the FCC's spurious emission standards when operated at the lesser of 1500 watts, or its full output power

E1F12 [97.201] Who may be the control operator of an auxiliary station?

Only Technician, General, Advanced or Amateur Extra Class operators

E1F13 [97.117] What types of communications may be transmitted to amateur stations in foreign countries?

Communications incidental to the purpose of the amateur service and remarks of a personal nature

E1F14 [1.931] Under what circumstances might the FCC issue a "Special Temporary Authority" (STA) to an amateur station?

To provide for experimental amateur communications

E2A01 What is the direction of an ascending pass for an amateur satellite?

From south to north

E2A02 What is the direction of a descending pass for an amateur satellite?

From north to south

E2A03 What is the orbital period of an Earth satellite?

The time it takes for a satellite to complete one revolution around the Earth

E2A04 What is meant by the term mode as applied to an amateur radio satellite?

The satellite's uplink and downlink frequency bands

E2A05 What do the letters in a satellite's mode designator specify?

The uplink and downlink frequency ranges

E2A06 On what band would a satellite receive signals if it were operating in mode U/V?

435-438 MHz

E2A07 Which of the following types of signals can be relayed through a linear transponder?

All of these choices are correct

E2A08 Why should effective radiated power to a satellite which uses a linear transponder be limited?

To avoid reducing the downlink power to all other users

E2A09 What do the terms L band and S band specify with regard to satellite communications?

The 23 centimeter and 13 centimeter bands

E2A10 Why may the received signal from an amateur satellite exhibit a rapidly repeating fading effect?

Because the satellite is spinning

E2A11 What type of antenna can be used to minimize the effects of spin modulation and Faraday rotation?

A circularly polarized antenna

E2A12 What is one way to predict the location of a satellite at a given time?

By calculations using the Keplerian elements for the specified satellite

E2A13 What type of satellite appears to stay in one position in the sky?

Geostationary

E2B01 How many times per second is a new frame transmitted in a fast-scan (NTSC) television system?

30

E2B02 How many horizontal lines make up a fast-scan (NTSC) television frame?

525

E2B03 How is an interlaced scanning pattern generated in a fast-scan (NTSC) television system?

By scanning odd numbered lines in one field and even numbered ones in the next

E2B04 What is blanking in a video signal?

Turning off the scanning beam while it is traveling from right to left or from bottom to top

E2B05 Which of the following is an advantage of using vestigial sideband for standard fast-scan TV transmissions?

Vestigial sideband reduces bandwidth while allowing for simple video detector circuitry

E2B06 What is vestigial sideband modulation?

Amplitude modulation in which one complete sideband and a portion of the other are transmitted

E2B07 What is the name of the signal component that carries color information in NTSC video?

Chroma

E2B08 Which of the following is a common method of transmitting accompanying audio with amateur fast-scan television?

All of these choices are correct

E2B09 What hardware, other than a receiver with SSB capability and a suitable computer, is needed to decode SSTV using Digital Radio Mondiale (DRM)?

No other hardware is needed

E2B10 Which of the following is an acceptable bandwidth for Digital Radio Mondiale (DRM) based voice or SSTV digital transmissions made on the HF amateur bands?

3 KHz

E2B11 What is the function of the Vertical Interval Signaling (VIS) code transmitted as part of an SSTV transmission?

To identify the SSTV mode being used

E2B12 How are analog SSTV images typically transmitted on the HF bands?

Varying tone frequencies representing the video are transmitted using single sideband

E2B13 How many lines are commonly used in each frame on an amateur slow-scan color television picture?

128 or 256

E2B14 What aspect of an amateur slow-scan television signal encodes the brightness of the picture?

Tone frequency

E2B15 What signals SSTV receiving equipment to begin a new picture line?

Specific tone frequencies

E2B16 Which of the following is the video standard used by North American Fast Scan ATV stations?

NTSC

E2B17 What is the approximate bandwidth of a slow-scan TV signal?

3 kHz

E2B18 On which of the following frequencies is one likely to find FM ATV transmissions?

1255 MHz

E2B19 What special operating frequency restrictions are imposed on slow scan TV transmissions?

They are restricted to phone band segments and their bandwidth can be no greater than that of a voice signal of the same modulation type

E2C01 Which of the following is true about contest operating?

Operators are permitted to make contacts even if they do not submit a log

E2C02 Which of the following best describes the term "self-spotting" in regards to contest operating?

The generally prohibited practice of posting one's own call sign and frequency on a call sign spotting network

E2C03 From which of the following bands is amateur radio contesting generally excluded?

30 meters

E2C04 On which of the following frequencies is an amateur radio contest contact generally discouraged?

146.52 MHz

E2C05 What is the function of a DX QSL Manager?

To handle the receiving and sending of confirmation cards for a DX station

E2C06 During a VHF/UHF contest, in which band segment would you expect to find the highest level of activity?

In the weak signal segment of the band, with most of the activity near the calling frequency

E2C07 What is the Cabrillo format?

A standard for submission of electronic contest logs

E2C08 Why are received spread-spectrum signals resistant to interference?

Signals not using the spectrum-spreading algorithm are suppressed in the receiver

E2C09 How does the spread-spectrum technique of frequency hopping work?

The frequency of the transmitted signal is changed very rapidly according to a particular sequence also used by the receiving station

E2C10 Why might a DX station state that they are listening on another frequency?

All of these choices are correct

E2C11 How should you generally identify your station when attempting to contact a DX station working a pileup or in a contest?

Send your full call sign once or twice

E2C12 What might help to restore contact when DX signals become too weak to copy across an entire HF band a few hours after sunset?

Switch to a lower frequency HF band

E2D01 Which of the following digital modes is especially designed for use for meteor scatter signals?

FSK441

E2D02 What is the definition of baud?

The number of data symbols transmitted per second

E2D03 Which of the following digital modes is especially useful for EME communications?

JT65

E2D04 What is the purpose of digital store-and-forward functions on an Amateur Radio satellite?

To store digital messages in the satellite for later download by other stations

E2D05 Which of the following techniques is normally used by low Earth orbiting digital satellites to relay messages around the world?

Store-and-forward

E2D06 Which of the following is a commonly used 2-meter APRS frequency?

144.39 MHz

E2D07 Which of the following digital protocols is used by APRS?

AX.25

E2D08 Which of the following types of packet frames is used to transmit APRS beacon data?

Unnumbered Information

E2D09 Under clear communications conditions, which of these digital communications modes has the fastest data throughput?

300-baud packet

E2D10 How can an APRS station be used to help support a public service communications activity?

An APRS station with a GPS unit can automatically transmit information to show a mobile station's position during the event

E2D11 Which of the following data are used by the APRS network to communicate your location?

Latitude and longitude

E2D12 How does JT65 improve EME communications?

It can decode signals many dB below the noise floor using FEC

E2E01 Which type of modulation is common for data emissions below 30 MHz?

FSK

E2E02 What do the letters FEC mean as they relate to digital operation?

Forward Error Correction

E2E03 How is Forward Error Correction implemented?

By transmitting extra data that may be used to detect and correct transmission errors

E2E04 What is indicated when one of the ellipses in an FSK crossed-ellipse display suddenly disappears?

Selective fading has occurred

E2E05 How does ARQ accomplish error correction?

If errors are detected, a retransmission is requested

E2E06 What is the most common data rate used for HF packet communications?

300 baud

E2E07 What is the typical bandwidth of a properly modulated MFSK16 signal?

316 Hz

E2E08 Which of the following HF digital modes can be used to transfer binary files?

PACTOR

E2E09 Which of the following HF digital modes uses variable-length coding for bandwidth efficiency?

PSK31

E2E10 Which of these digital communications modes has the narrowest bandwidth?

PSK31

E2E11 What is the difference between direct FSK and audio FSK?

Direct FSK applies the data signal to the transmitter VFO

E2E12 Which type of digital communication does not support keyboard-to-keyboard operation?

Winlink

E3A01 What is the approximate maximum separation measured along the surface of the Earth between two stations communicating by Moon bounce?

12,000 miles, as long as both can "see" the Moon

E3A02 What characterizes libration fading of an Earth-Moon-Earth signal?

A fluttery irregular fading

E3A03 When scheduling EME contacts, which of these conditions will generally result in the least path loss?

When the Moon is at perigee

E3A04 What type of receiving system is desirable for EME communications?

Equipment with very low noise figures

E3A05 Which of the following describes a method of establishing EME contacts?

Time synchronous transmissions with each station alternating

E3A06 What frequency range would you normally tune to find EME signals in the 2 meter band?

144.000 - 144.100 MHz

E3A07 What frequency range would you normally tune to find EME signals in the 70 cm band?

432.000 - 432.100 MHz

E3A08 When a meteor strikes the Earth's atmosphere, a cylindrical region of free electrons is formed at what layer of the ionosphere?

The E layer

E3A09 Which of the following frequency ranges is well suited for meteor-scatter communications?

28 - 148 MHz

E3A10 Which of the following is a good technique for making meteor-scatter contacts?

All of these choices are correct

E3B01 What is transequatorial propagation?

Propagation between two mid-latitude points at approximately the same distance north and south of the magnetic equator

E3B02 What is the approximate maximum range for signals using transequatorial propagation?

5000 miles

E3B03 What is the best time of day for transequatorial propagation?

Afternoon or early evening

E3B04 What type of propagation is probably occurring if an HF beam antenna must be pointed in a direction 180 degrees away from a station to receive the strongest signals?

Long-path

E3B05 Which amateur bands typically support long-path propagation?

160 to 10 meters

E3B06 Which of the following amateur bands most frequently provides long-path propagation?

20 meters

E3B07 Which of the following could account for hearing an echo on the received signal of a distant station?

Receipt of a signal by more than one path

E3B08 What type of HF propagation is probably occurring if radio signals travel along the terminator between daylight and darkness?

Gray-line

E3B09 At what time of day is gray-line propagation most likely to occur?

At sunrise and sunset

E3B10 What is the cause of gray-line propagation?

At twilight, D-layer absorption drops while E-layer and F-layer propagation remain strong

E3B11 Which of the following describes gray-line propagation?

Long distance communications at twilight on frequencies less than 15 MHz

E3C01 Which of the following effects does Aurora activity have on radio communications?

All of these choices are correct

E3C02 What is the cause of Aurora activity?

The interaction of charged particles from the Sun with the Earth's magnetic field and the ionosphere

E3C03 Where in the ionosphere does Aurora activity occur?

In the E-region

E3C04 Which emission mode is best for Aurora propagation?

CW

E3C05 Which of the following describes selective fading?

Partial cancellation of some frequencies within the received pass band

E3C06 By how much does the VHF/UHF radio-path horizon distance exceed the geometric horizon?

By approximately 15% of the distance

E3C07 How does the radiation pattern of a horizontally polarized 3-element beam antenna vary with its height above ground?

The main lobe takeoff angle decreases with increasing height

E3C08 What is the name of the high-angle wave in HF propagation that travels for some distance within the F2 region?

Pedersen ray

E3C09 Which of the following is usually responsible for causing VHF signals to propagate for hundreds of miles?

Tropospheric ducting

E3C10 How does the performance of a horizontally polarized antenna mounted on the side of a hill compare with the same antenna mounted on flat ground?

The main lobe takeoff angle decreases in the downhill direction

E3C11 From the contiguous 48 states, in which approximate direction should an antenna be pointed to take maximum advantage of aurora propagation?

North

E3C12 How does the maximum distance of ground-wave propagation change when the signal frequency is increased?

It decreases

E3C13 What type of polarization is best for ground-wave propagation?

Vertical

E3C14 Why does the radio-path horizon distance exceed the geometric horizon?

Downward bending due to density variations in the atmosphere

E4A01 How does a spectrum analyzer differ from an oscilloscope?

A spectrum analyzer displays signals in the frequency domain; an oscilloscope displays signals in the time domain

E4A02 Which of the following parameters would a spectrum analyzer display on the horizontal axis?

Frequency

E4A03 Which of the following parameters would a spectrum analyzer display on the vertical axis?

Amplitude

E4A04

Which of the following test instruments is used to display spurious signals from a radio transmitter?

A spectrum analyzer

E4A05 Which of the following test instruments is used to display intermodulation distortion products in an SSB transmission?

A spectrum analyzer

E4A06 Which of the following could be determined with a spectrum analyzer?

All of these choices are correct

E4A07 Which of the following is an advantage of using an antenna analyzer compared to an SWR bridge to measure antenna SWR?

Antenna analyzers do not need an external RF source

E4A08 Which of the following instruments would be best for measuring the SWR of a beam antenna?

An antenna analyzer

E4A09 Which of the following describes a good method for measuring the intermodulation distortion of your own PSK signal?

Transmit into a dummy load, receive the signal on a second receiver, and feed the audio into the sound card of a computer running an appropriate PSK program

E4A10 Which of the following tests establishes that a silicon NPN junction transistor is biased on?

Measure base-to-emitter voltage with a voltmeter; it should be approximately 0.6 to 0.7 volts

E4A11 Which of these instruments could be used for detailed analysis of digital signals?

Oscilloscope

E4A12 Which of the following procedures is an important precaution to follow when connecting a spectrum analyzer to a transmitter output?

Attenuate the transmitter output going to the spectrum analyzer

E4B01 Which of the following factors most affects the accuracy of a frequency counter?

Time base accuracy

E4B02 What is an advantage of using a bridge circuit to measure impedance?

The measurement is based on obtaining a signal null, which can be done very precisely

E4B03 If a frequency counter with a specified accuracy of +/- 1.0 ppm reads 146,520,000 Hz, what is the most the actual frequency being measured could differ from the reading?

146.52 Hz

E4B04 If a frequency counter with a specified accuracy of +/- 0.1 ppm reads 146,520,000 Hz, what is the most the actual frequency being measured could differ from the reading?

14.652 Hz

E4B05 If a frequency counter with a specified accuracy of +/- 10 ppm reads 146,520,000 Hz, what is the most the actual frequency being measured could differ from the reading?

1465.20 Hz

E4B06 How much power is being absorbed by the load when a directional power meter connected between a transmitter and a terminating load reads 100 watts forward power and 25 watts reflected power?

75 watts

E4B07 Which of the following is good practice when using an oscilloscope probe?

Keep the signal ground connection of the probe as short as possible

E4B08 Which of the following is a characteristic of a good DC voltmeter?

High impedance input

E4B09 What is indicated if the current reading on an RF ammeter placed in series with the antenna feed line of a transmitter increases as the transmitter is tuned to resonance?

There is more power going into the antenna

E4B10 Which of the following describes a method to measure intermodulation distortion in an SSB transmitter?

Modulate the transmitter with two non-harmonically related audio frequencies and observe the RF output with a spectrum analyzer

E4B11 How should a portable antenna analyzer be connected when measuring antenna resonance and feed point impedance?

Connect the antenna feed line directly to the analyzer's connector

E4B12 What is the significance of voltmeter sensitivity expressed in ohms per volt?

The full scale reading of the voltmeter multiplied by its ohms per volt rating will provide the input impedance of the voltmeter

E4B13 How is the compensation of an oscilloscope probe typically adjusted?

A square wave is displayed and the probe is adjusted until the horizontal portions of the displayed wave are as nearly flat as possible

E4B14 What happens if a dip meter is too tightly coupled to a tuned circuit being checked?

A less accurate reading results

E4B15 Which of the following can be used as a relative measurement of the Q for a series-tuned circuit?

The bandwidth of the circuit's frequency response

E4C01 What is an effect of excessive phase noise in the local oscillator section of a receiver?

It can cause strong signals on nearby frequencies to interfere with reception of weak signals

E4C02 Which of the following portions of a receiver can be effective in eliminating image signal interference?

A front-end filter or pre-selector

E4C03 What is the term for the blocking of one FM phone signal by another, stronger FM phone signal?

Capture effect

E4C04 What is the definition of the noise figure of a receiver?

The ratio in dB of the noise generated by the receiver compared to the theoretical minimum noise

E4C05 What does a value of -174 dBm/Hz represent with regard to the noise floor of a receiver?

The theoretical noise at the input of a perfect receiver at room temperature

E4C06 A CW receiver with the AGC off has an equivalent input noise power density of -174 dBm/Hz. What would be the level of an unmodulated carrier input to this receiver that would yield an audio output SNR of 0 dB in a 400 Hz noise bandwidth?

-148 dBm

E4C07 What does the MDS of a receiver represent?

The minimum discernible signal

E4C08 How might lowering the noise figure affect receiver performance?

It would improve weak signal sensitivity

E4C09 Which of the following choices is a good reason for selecting a high frequency for the design of the IF in a conventional HF or VHF communications receiver?

Easier for front-end circuitry to eliminate image responses

E4C10 Which of the following is a desirable amount of selectivity for an amateur RTTY HF receiver?

300 Hz

E4C11 Which of the following is a desirable amount of selectivity for an amateur SSB phone receiver?

2.4 kHz

E4C12 What is an undesirable effect of using too wide a filter bandwidth in the IF section of a receiver?

Undesired signals may be heard

E4C13 How does a narrow-band roofing filter affect receiver performance?

It improves dynamic range by attenuating strong signals near the receive frequency

E4C14 On which of the following frequencies might a signal be transmitting which is generating a spurious image signal in a receiver tuned to 14.300 MHz and which uses a 455 kHz IF frequency?

15.210 MHz

E4C15 What is the primary source of noise that can be heard from an HF receiver with an antenna connected?

Atmospheric noise

E4D01 What is meant by the blocking dynamic range of a receiver?

The difference in dB between the noise floor and the level of an incoming signal which will cause 1 dB of gain compression

E4D02 Which of the following describes two problems caused by poor dynamic range in a communications receiver?

Cross-modulation of the desired signal and desensitization from strong adjacent signals

E4D03 How can intermodulation interference between two repeaters occur?

When the repeaters are in close proximity and the signals mix in the final amplifier of one or both transmitters

E4D04 Which of the following may reduce or eliminate intermodulation interference in a repeater caused by another transmitter operating in close proximity?

A properly terminated circulator at the output of the transmitter

E4D05 What transmitter frequencies would cause an intermodulation-product signal in a receiver tuned to 146.70 MHz when a nearby station transmits on 146.52 MHz?

146.34 MHz and 146.61 MHz

E4D06 What is the term for unwanted signals generated by the mixing of two or more signals?

Intermodulation interference

E4D07 Which of the following describes the most significant effect of an off-frequency signal when it is causing cross-modulation interference to a desired signal?

The off-frequency unwanted signal is heard in addition to the desired signal

E4D08 What causes intermodulation in an electronic circuit?

Nonlinear circuits or devices

E4D09 What is the purpose of the preselector in a communications receiver?

To increase rejection of unwanted signals

E4D10 What does a third-order intercept level of 40 dBm mean with respect to receiver performance?

A pair of 40 dBm signals will theoretically generate a third-order intermodulation product with the same level as the input signals

E4D11 Why are third-order intermodulation products created within a receiver of particular interest compared to other products?

The third-order product of two signals which are in the band of interest is also likely to be within the band

E4D12 What is the term for the reduction in receiver sensitivity caused by a strong signal near the received frequency?

Desensitization

E4D13 Which of the following can cause receiver desensitization?

Strong adjacent-channel signals

E4D14 Which of the following is a way to reduce the likelihood of receiver desensitization?

Decrease the RF bandwidth of the receiver

E4E01 Which of the following types of receiver noise can often be reduced by use of a receiver noise blanker?

Ignition noise

E4E02 Which of the following types of receiver noise can often be reduced with a DSP noise filter?

All of these choices are correct

E4E03 Which of the following signals might a receiver noise blanker be able to remove from desired signals?

Signals which appear across a wide bandwidth

E4E04 How can conducted and radiated noise caused by an automobile alternator be suppressed?

By connecting the radio's power leads directly to the battery and by installing coaxial capacitors in line with the alternator leads

E4E05 How can noise from an electric motor be suppressed?

By installing a brute-force AC-line filter in series with the motor leads

E4E06 What is a major cause of atmospheric static?

Thunderstorms

E4E07 How can you determine if line noise interference is being generated within your home?

By turning off the AC power line main circuit breaker and listening on a battery operated radio

E4E08 What type of signal is picked up by electrical wiring near a radio antenna?

A common-mode signal at the frequency of the radio transmitter

E4E09 What undesirable effect can occur when using an IF noise blanker?

Nearby signals may appear to be excessively wide even if they meet emission standards

E4E10 What is a common characteristic of interference caused by a touch controlled electrical device?

All of these choices are correct

E4E11 Which of the following is the most likely cause if you are hearing combinations of local AM broadcast signals within one or more of the MF or HF ham bands?

Nearby corroded metal joints are mixing and re-radiating the broadcast signals

E4E12 What is one disadvantage of using some types of automatic DSP notch-filters when attempting to copy CW signals?

The DSP filter can remove the desired signal at the same time as it removes interfering signals

E4E13 What might be the cause of a loud roaring or buzzing AC line interference that comes and goes at intervals?

All of these choices are correct

E4E14 What is one type of electrical interference that might be caused by the operation of a nearby personal computer?

The appearance of unstable modulated or unmodulated signals at specific frequencies

E5A01 What can cause the voltage across reactances in series to be larger than the voltage applied to them?

Resonance

E5A02 What is resonance in an electrical circuit?

The frequency at which the capacitive reactance equals the inductive reactance

E5A03 What is the magnitude of the impedance of a series RLC circuit at resonance?

Approximately equal to circuit resistance

E5A04 What is the magnitude of the impedance of a circuit with a resistor, an inductor and a capacitor all in parallel, at resonance?

Approximately equal to circuit resistance

E5A05 What is the magnitude of the current at the input of a series RLC circuit as the frequency goes through resonance?

Maximum

E5A06 What is the magnitude of the circulating current within the components of a parallel LC circuit at resonance?

It is at a maximum

E5A07

What is the magnitude of the current at the input of a parallel RLC circuit at resonance?

Minimum

E5A08 What is the phase relationship between the current through and the voltage across a series resonant circuit at resonance?

The voltage and current are in phase

E5A09 What is the phase relationship between the current through and the voltage across a parallel resonant circuit at resonance?

The voltage and current are in phase

E5A10 What is the half-power bandwidth of a parallel resonant circuit that has a resonant frequency of 1.8 MHz and a Q of 95?

18.9 kHz

E5A11 What is the half-power bandwidth of a parallel resonant circuit that has a resonant frequency of 7.1 MHz and a Q of 150?

47.3 kHz

E5A12 What is the half-power bandwidth of a parallel resonant circuit that has a resonant frequency of 3.7 MHz and a Q of 118?

31.4 kHz

E5A13 What is the half-power bandwidth of a parallel resonant circuit that has a resonant frequency of 14.25 MHz and a Q of 187?

76.2 kHz

E5A14 What is the resonant frequency of a series RLC circuit if R is 22 ohms, L is 50 microhenrys and C is 40 picofarads?

3.56 MHz

E5A15 What is the resonant frequency of a series RLC circuit if R is 56 ohms, L is 40 microhenrys and C is 200 picofarads?

1.78 MHz

E5A16 What is the resonant frequency of a parallel RLC circuit if R is 33 ohms, L is 50 microhenrys and C is 10 picofarads?

7.12 MHz

E5A17 What is the resonant frequency of a parallel RLC circuit if R is 47 ohms, L is 25 microhenrys and C is 10 picofarads?

10.1 MHz

E5B01 What is the term for the time required for the capacitor in an RC circuit to be charged to 63.2% of the applied voltage?

One time constant

E5B02 What is the term for the time it takes for a charged capacitor in an RC circuit to discharge to 36.8% of its initial voltage?

One time constant

E5B03 The capacitor in an RC circuit is discharged to what percentage of the starting voltage after two time constants?

13.5%

E5B04 What is the time constant of a circuit having two 220-microfarad capacitors and two 1-megohm resistors, all in parallel?

220 seconds

E5B05 How long does it take for an initial charge of 20 V DC to decrease to 7.36 V DC in a 0.01-microfarad capacitor when a 2-megohm resistor is connected across it?

0.02 seconds

E5B06 How long does it take for an initial charge of 800 V DC to decrease to 294 V DC in a 450-microfarad capacitor when a 1-megohm resistor is connected across it?

450 seconds

E5B07 What is the phase angle between the voltage across and the current through a series RLC circuit if XC is 500 ohms, R is 1 kilohm, and XL is 250 ohms?

14.0 degrees with the voltage lagging the current

E5B08 What is the phase angle between the voltage across and the current through a series RLC circuit if XC is 100 ohms, R is 100 ohms, and XL is 75 ohms?

14 degrees with the voltage lagging the current

E5B09 What is the relationship between the current through a capacitor and the voltage across a capacitor?

Current leads voltage by 90 degrees

E5B10 What is the relationship between the current through an inductor and the voltage across an inductor?

Voltage leads current by 90 degrees

E5B11 What is the phase angle between the voltage across and the current through a series RLC circuit if XC is 25 ohms, R is 100 ohms, and XL is 50 ohms?

14 degrees with the voltage leading the current

E5B12 What is the phase angle between the voltage across and the current through a series RLC circuit if XC is 75 ohms, R is 100 ohms, and XL is 50 ohms?

14 degrees with the voltage lagging the current

E5B13 What is the phase angle between the voltage across and the current through a series RLC circuit if X_C is 250 ohms, R is 1 kilohm, and X_L is 500 ohms?

14.04 degrees with the voltage leading the current

E5C01 In polar coordinates, what is the impedance of a network consisting of a 100-ohm-reactance inductor in series with a 100-ohm resistor?

141 ohms at an angle of 45 degrees

E5C02 In polar coordinates, what is the impedance of a network consisting of a 100-ohm-reactance inductor, a 100-ohm-reactance capacitor, and a 100-ohm resistor, all connected in series?

100 ohms at an angle of 0 degrees

E5C03 In polar coordinates, what is the impedance of a network consisting of a 300-ohm-reactance capacitor, a 600-ohm-reactance inductor, and a 400-ohm resistor, all connected in series?

500 ohms at an angle of 37 degrees

E5C04 In polar coordinates, what is the impedance of a network consisting of a 400-ohm-reactance capacitor in series with a 300-ohm resistor?

500 ohms at an angle of -53.1 degrees

E5C05 In polar coordinates, what is the impedance of a network consisting of a 400-ohm-reactance inductor in parallel with a 300-ohm resistor?

240 ohms at an angle of 36.9 degrees

E5C06 In polar coordinates, what is the impedance of a network consisting of a 100-ohm-reactance capacitor in series with a 100-ohm resistor?

141 ohms at an angle of -45 degrees

E5C07 In polar coordinates, what is the impedance of a network comprised of a 100-ohm-reactance capacitor in parallel with a 100-ohm resistor?

71 ohms at an angle of -45 degrees

E5C08 In polar coordinates, what is the impedance of a network comprised of a 300-ohm-reactance inductor in series with a 400-ohm resistor?

500 ohms at an angle of 37 degrees

E5C09 When using rectangular coordinates to graph the impedance of a circuit, what does the horizontal axis represent?

Resistive component

E5C10 When using rectangular coordinates to graph the impedance of a circuit, what does the vertical axis represent?

Reactive component

E5C11 What do the two numbers represent that are used to define a point on a graph using rectangular coordinates?

The coordinate values along the horizontal and vertical axes

E5C12 If you plot the impedance of a circuit using the rectangular coordinate system and find the impedance point falls on the right side of the graph on the horizontal axis, what do you know about the circuit?

It is equivalent to a pure resistance

E5C13 What coordinate system is often used to display the resistive, inductive, and/or capacitive reactance components of an impedance?

Rectangular coordinates

E5C14 What coordinate system is often used to display the phase angle of a circuit containing resistance, inductive and/or capacitive reactance?

Polar coordinates

E5C15 In polar coordinates, what is the impedance of a circuit of 100 -j100 ohms impedance?

141 ohms at an angle of -45 degrees

E5C16 In polar coordinates, what is the impedance of a circuit that has an admittance of 7.09 millisiemens at 45 degrees?

141 ohms at an angle of -45 degrees

E5C17 In rectangular coordinates, what is the impedance of a circuit that has an admittance of 5 millisiemens at -30 degrees?

173 +j100 ohms

E5C18 In polar coordinates, what is the impedance of a series circuit consisting of a resistance of 4 ohms, an inductive reactance of 4 ohms, and a capacitive reactance of 1 ohm?

5 ohms at an angle of 37 degrees

E5C19 Which point on Figure E5-2 best represents that impedance of a series circuit consisting of a 400 ohm resistor and a 38 picofarad capacitor at 14 MHz?

Point 4

E5C20 Which point in Figure E5-2 best represents the impedance of a series circuit consisting of a 300 ohm resistor and an 18 microhenry inductor at 3.505 MHz?

Point 3

E5C21 Which point on Figure E5-2 best represents the impedance of a series circuit consisting of a 300 ohm resistor and a 19 picofarad capacitor at 21.200 MHz?

Point 1

E5C22 In rectangular coordinates, what is the impedance of a network consisting of a 10-microhenry inductor in series with a 40-ohm resistor at 500 MHz?

40 + j31,400

E5C23 Which point on Figure E5-2 best represents the impedance of a series circuit consisting of a 300-ohm resistor, a 0.64-microhenry inductor and an 85-picofarad capacitor at 24.900 MHz?

Point 8

E5D01 What is the result of skin effect?

As frequency increases, RF current flows in a thinner layer of the conductor, closer to the surface

E5D02 Why is the resistance of a conductor different for RF currents than for direct currents?

Because of skin effect

E5D03 What device is used to store electrical energy in an electrostatic field?

A capacitor

E5D04 What unit measures electrical energy stored in an electrostatic field?

Joule

E5D05 Which of the following creates a magnetic field?

Electric current

E5D06 In what direction is the magnetic field oriented about a conductor in relation to the direction of electron flow?

In a direction determined by the left-hand rule

E5D07 What determines the strength of a magnetic field around a conductor?

The amount of current

E5D08 What type of energy is stored in an electromagnetic or electrostatic field?

Potential energy

E5D09 What happens to reactive power in an AC circuit that has both ideal inductors and ideal capacitors?

It is repeatedly exchanged between the associated magnetic and electric fields, but is not dissipated

E5D10 How can the true power be determined in an AC circuit where the voltage and current are out of phase?

By multiplying the apparent power times the power factor

E5D11 What is the power factor of an R-L circuit having a 60 degree phase angle between the voltage and the current?

0.5

E5D12 How many watts are consumed in a circuit having a power factor of 0.2 if the input is 100-V AC at 4 amperes?

80 watts

E5D13 How much power is consumed in a circuit consisting of a 100 ohm resistor in series with a 100 ohm inductive reactance drawing 1 ampere?

100 Watts

E5D14 What is reactive power?

Wattless, nonproductive power

E5D15 What is the power factor of an RL circuit having a 45 degree phase angle between the voltage and the current?

0.707

E5D16 What is the power factor of an RL circuit having a 30 degree phase angle between the voltage and the current?

0.866

E5D17 How many watts are consumed in a circuit having a power factor of 0.6 if the input is 200V AC at 5 amperes?

600 watts

E5D18 How many watts are consumed in a circuit having a power factor of 0.71 if the apparent power is 500 VA?

355 W

E6A01 In what application is gallium arsenide used as a semiconductor material in preference to germanium or silicon?

At microwave frequencies

E6A02 Which of the following semiconductor materials contains excess free electrons?

N-type

E6A03 What are the majority charge carriers in P-type semiconductor material?

Holes

E6A04 What is the name given to an impurity atom that adds holes to a semiconductor crystal structure?

Acceptor impurity

E6A05 What is the alpha of a bipolar junction transistor?

The change of collector current with respect to emitter current

E6A06 What is the beta of a bipolar junction transistor?

The change in collector current with respect to base current

E6A07 In Figure E6-1, what is the schematic symbol for a PNP transistor?

1

E6A08 What term indicates the frequency at which the grounded-base current gain of a transistor has decreased to 0.7 of the gain obtainable at 1 kHz?

Alpha cutoff frequency

E6A09 What is a depletion-mode FET?

An FET that exhibits a current flow between source and drain when no gate voltage is applied

E6A10 In Figure E6-2, what is the schematic symbol for an N-channel dual-gate MOSFET?

4

E6A11 In Figure E6-2, what is the schematic symbol for a P-channel junction FET?

1

E6A12 Why do many MOSFET devices have internally connected Zener diodes on the gates?

To reduce the chance of the gate insulation being punctured by static discharges or excessive voltages

E6A13 What do the initials CMOS stand for?

Complementary Metal-Oxide Semiconductor

E6A14 How does DC input impedance at the gate of a field-effect transistor compare with the DC input impedance of a bipolar transistor?

An FET has high input impedance; a bipolar transistor has low input impedance

E6A15 Which of the following semiconductor materials contains an excess of holes in the outer shell of electrons?

P-type

E6A16 What are the majority charge carriers in N-type semiconductor material?

Free electrons

E6A17 What are the names of the three terminals of a field-effect transistor?

Gate, drain, source

E6B01 What is the most useful characteristic of a Zener diode?

A constant voltage drop under conditions of varying current

E6B02 What is an important characteristic of a Schottky diode as compared to an ordinary silicon diode when used as a power supply rectifier?

Less forward voltage drop

E6B03 What special type of diode is capable of both amplification and oscillation?

Tunnel

E6B04 What type of semiconductor device is designed for use as a voltage-controlled capacitor?

Varactor diode

E6B05 What characteristic of a PIN diode makes it useful as an RF switch or attenuator?

A large region of intrinsic material

E6B06 Which of the following is a common use of a hot-carrier diode?

As a VHF / UHF mixer or detector

E6B07 What is the failure mechanism when a junction diode fails due to excessive current?

Excessive junction temperature

E6B08 Which of the following describes a type of semiconductor diode?

Metal-semiconductor junction

E6B09 What is a common use for point contact diodes?

As an RF detector

E6B10 In Figure E6-3, what is the schematic symbol for a light-emitting diode?

5

E6B11 What is used to control the attenuation of RF signals by a PIN diode?

Forward DC bias current

E6B12 What is one common use for PIN diodes?

As an RF switch

E6B13 What type of bias is required for an LED to emit light?

Forward bias

E6C01 What is the recommended power supply voltage for TTL series integrated circuits?

5 volts

E6C02 What logic state do the inputs of a TTL device assume if they are left open?

A logic-high state

E6C03 Which of the following describes tri-state logic?

Logic devices with 0, 1, and high impedance output states

E6C04 Which of the following is the primary advantage of tri-state logic?

Ability to connect many device outputs to a common bus

E6C05 Which of the following is an advantage of CMOS logic devices over TTL devices?

Lower power consumption

E6C06 Why do CMOS digital integrated circuits have high immunity to noise on the input signal or power supply?

The input switching threshold is about one-half the power supply voltage

E6C07 In Figure E6-5, what is the schematic symbol for an AND gate?

1

E6C08 In Figure E6-5, what is the schematic symbol for a NAND gate?

2

E6C09 In Figure E6-5, what is the schematic symbol for an OR gate?

3

E6C10 In Figure E6-5, what is the schematic symbol for a NOR gate?

4

E6C11 In Figure E6-5, what is the schematic symbol for the NOT operation (inverter)?

5

E6C12 What is BiCMOS logic?

An integrated circuit logic family using both bipolar and CMOS transistors

E6C13 Which of the following is an advantage of BiCMOS logic?

It has the high input impedance of CMOS and the low output impedance of bipolar transistors

E6D01 What is cathode ray tube (CRT) persistence?

The length of time the image remains on the screen after the beam is turned off

E6D02 Exceeding what design rating can cause a cathode ray tube (CRT) to generate X-rays?

The anode voltage

E6D03 Which of the following is true of a charge-coupled device (CCD)?

It samples an analog signal and passes it in stages from the input to the output

E6D04 What function does a charge-coupled device (CCD) serve in a modern video camera?

It stores photogenerated charges as signals corresponding to pixels

E6D05 What is a liquid-crystal display (LCD)?

A display using a crystalline liquid which, in conjunction with polarizing filters, becomes opaque when voltage is applied

E6D06 What core material property determines the inductance of a toroidal inductor?

Permeability

E6D07 What is the usable frequency range of inductors that use toroidal cores, assuming a correct selection of core material for the frequency being used?

From less than 20 Hz to approximately 300 MHz

E6D08 What is one important reason for using powdered-iron toroids rather than ferrite toroids in an inductor?

Powdered-iron toroids generally maintain their characteristics at higher currents

E6D09 What devices are commonly used as VHF and UHF parasitic suppressors at the input and output terminals of transistorized HF amplifiers?

Ferrite beads

E6D10 What is a primary advantage of using a toroidal core instead of a solenoidal core in an inductor?

Toroidal cores confine most of the magnetic field within the core material

E6D11 How many turns will be required to produce a 1-mH inductor using a ferrite toroidal core that has an inductance index (A L) value of 523 millihenrys/1000 turns?

43 turns

E6D12 How many turns will be required to produce a 5-microhenry inductor using a powdered-iron toroidal core that has an inductance index (A L) value of 40 microhenrys/100 turns?

35 turns

E6D13 What type of CRT deflection is better when high-frequency waveforms are to be displayed on the screen?

Electrostatic

E6D14 Which is NOT true of a charge-coupled device (CCD)?

It is commonly used as an analog-to-digital converter

E6D15 What is the principle advantage of liquid-crystal display (LCD) devices over other types of display devices?

They consume less power

E6D16 What is one reason for using ferrite toroids rather than powdered-iron toroids in an inductor?

Ferrite toroids generally require fewer turns to produce a given inductance value

E6E01 What is a crystal lattice filter?

A filter with narrow bandwidth and steep skirts made using quartz crystals

E6E02 Which of the following factors has the greatest effect in helping determine the bandwidth and response shape of a crystal ladder filter?

The relative frequencies of the individual crystals

E6E03 What is one aspect of the piezoelectric effect?

Physical deformation of a crystal by the application of a voltage

E6E04 What is the most common input and output impedance of circuits that use MMICs?

50 ohms

E6E05 Which of the following noise figure values is typical of a low-noise UHF preamplifier?

2 dB

E6E06 What characteristics of the MMIC make it a popular choice for VHF through microwave circuits?

Controlled gain, low noise figure, and constant input and output impedance over the specified frequency range

E6E07 Which of the following is typically used to construct a MMIC-based microwave amplifier?

Microstrip construction

E6E08 How is power-supply voltage normally furnished to the most common type of monolithic microwave integrated circuit (MMIC)?

Through a resistor and/or RF choke connected to the amplifier output lead

E6E09 Which of the following must be done to insure that a crystal oscillator provides the frequency specified by the crystal manufacturer?

Provide the crystal with a specified parallel capacitance

E6E10 What is the equivalent circuit of a quartz crystal?

Motional capacitance, motional inductance and loss resistance in series, with a shunt capacitance representing electrode and stray capacitance

E6E11 Which of the following materials is likely to provide the highest frequency of operation when used in MMICs?

Gallium nitride

E6E12 What is a "Jones filter" as used as part of a HF receiver IF stage?

A variable bandwidth crystal lattice filter

E6F01 What is photoconductivity?

The increased conductivity of an illuminated semiconductor

E6F02 What happens to the conductivity of a photoconductive material when light shines on it?

It increases

E6F03 What is the most common configuration of an optoisolator or optocoupler?

An LED and a phototransistor

E6F04 What is the photovoltaic effect?

The conversion of light to electrical energy

E6F05 Which of the following describes an optical shaft encoder?

A device which detects rotation of a control by interrupting a light source with a patterned wheel

E6F06 Which of these materials is affected the most by photoconductivity?

A crystalline semiconductor

E6F07 What is a solid state relay?

A device that uses semiconductor devices to implement the functions of an electromechanical relay

E6F08 Why are optoisolators often used in conjunction with solid state circuits when switching 120 VAC?

Optoisolators provide a very high degree of electrical isolation between a control circuit and the circuit being switched

E6F09 What is the efficiency of a photovoltaic cell?

The relative fraction of light that is converted to current

E6F10 What is the most common type of photovoltaic cell used for electrical power generation?

Silicon

E6F11 Which of the following is the approximate open-circuit voltage produced by a fully-illuminated silicon photovoltaic cell?

0.5 V

E6F12 What absorbs the energy from light falling on a photovoltaic cell?

Electrons

E7A01 Which of the following is a bistable circuit?

A flip-flop

E7A02 How many output level changes are obtained for every two trigger pulses applied to the input of a T flip-flop circuit?

Two

E7A03 Which of the following can divide the frequency of a pulse train by 2?

A flip-flop

E7A04 How many flip-flops are required to divide a signal frequency by 4?

2

E7A05 Which of the following is a circuit that continuously alternates between two states without an external clock?

Astable multivibrator

E7A06 What is a characteristic of a monostable multivibrator?

It switches momentarily to the opposite binary state and then returns, after a set time, to its original state

E7A07 What logical operation does a NAND gate perform?

It produces a logic "0" at its output only when all inputs are logic "1"

E7A08 What logical operation does an OR gate perform?

It produces a logic "1" at its output if any or all inputs are logic "1"

E7A09 What logical operation is performed by a two-input exclusive NOR gate?

It produces a logic "0" at its output if any single input is a logic "1"

E7A10 What is a truth table?

A list of inputs and corresponding outputs for a digital device

E7A11 What is the name for logic which represents a logic "1" as a high voltage?

Positive Logic

E7A12 What is the name for logic which represents a logic "0" as a high voltage?

Negative logic

E7A13 What is an SR or RS flip-flop?

A set/reset flip-flop whose output is low when R is high and S is low, high when S is high and R is low, and unchanged when both inputs are low

E7A14 What is a JK flip-flop?

A flip-flop similar to an RS except that it toggles when both J and K are high

E7A15 What is a D flip-flop?

A flip-flop whose output takes on the state of the D input when the clock signal transitions from low to high

E7B01 For what portion of a signal cycle does a Class AB amplifier operate?

More than 180 degrees but less than 360 degrees

E7B02 What is a Class D amplifier?

A type of amplifier that uses switching technology to achieve high efficiency

E7B03 Which of the following forms the output of a class D amplifier circuit?

A low-pass filter to remove switching signal components

E7B04 Where on the load line of a Class A common emitter amplifier would bias normally be set?

Approximately half-way between saturation and cutoff

E7B05 What can be done to prevent unwanted oscillations in an RF power amplifier?

Install parasitic suppressors and/or neutralize the stage

E7B06 Which of the following amplifier types reduces or eliminates even-order harmonics?

Push-pull

E7B07 Which of the following is a likely result when a Class C amplifier is used to amplify a single-sideband phone signal?

Signal distortion and excessive bandwidth

E7B08 How can an RF power amplifier be neutralized?

By feeding a 180-degree out-of-phase portion of the output back to the input

E7B09 Which of the following describes how the loading and tuning capacitors are to be adjusted when tuning a vacuum tube RF power amplifier that employs a pi-network output circuit?

The tuning capacitor is adjusted for minimum plate current, while the loading capacitor is adjusted for maximum permissible plate current

E7B10 In Figure E7-1, what is the purpose of R1 and R2?

Fixed bias

E7B11 In Figure E7-1, what is the purpose of R3?

Self bias

E7B12 What type of circuit is shown in Figure E7-1?

Common emitter amplifier

E7B13 In Figure E7-2, what is the purpose of R?

Emitter load

E7B14 In Figure E7-2, what is the purpose of C2?

Output coupling

E7B15 What is one way to prevent thermal runaway in a bipolar transistor amplifier?

Use a resistor in series with the emitter

E7B16 What is the effect of intermodulation products in a linear power amplifier?

Transmission of spurious signals

E7B17 Why are third-order intermodulation distortion products of particular concern in linear power amplifiers?

Because they are relatively close in frequency to the desired signal

E7B18 Which of the following is a characteristic of a grounded-grid amplifier?

Low input impedance

E7B19 What is a klystron?

A VHF, UHF, or microwave vacuum tube that uses velocity modulation

E7B20 What is a parametric amplifier?

A low-noise VHF or UHF amplifier relying on varying reactance for amplification

E7B21 Which of the following devices is generally best suited for UHF or microwave power amplifier applications?

Field effect transistor

E7C01 How are the capacitors and inductors of a low-pass filter Pi-network arranged between the network's input and output?

A capacitor is connected between the input and ground, another capacitor is connected between the output and ground, and an inductor is connected between input and output

E7C02 A T-network with series capacitors and a parallel shunt inductor has which of the following properties?

It is a high-pass filter

E7C03 What advantage does a Pi-L-network have over a Pi-network for impedance matching between the final amplifier of a vacuum-tube transmitter and an antenna?

Greater harmonic suppression

E7C04 How does an impedance-matching circuit transform a complex impedance to a resistive impedance?

It cancels the reactive part of the impedance and changes the resistive part to a desired value

E7C05 Which filter type is described as having ripple in the passband and a sharp cutoff?

A Chebyshev filter

E7C06 What are the distinguishing features of an elliptical filter?

Extremely sharp cutoff with one or more notches in the stop band

E7C07 What kind of filter would you use to attenuate an interfering carrier signal while receiving an SSB transmission?

A notch filter

E7C08 What kind of digital signal processing audio filter might be used to remove unwanted noise from a received SSB signal?

An adaptive filter

E7C09 What type of digital signal processing filter might be used to generate an SSB signal?

A Hilbert-transform filter

E7C10 Which of the following filters would be the best choice for use in a 2 meter repeater duplexer?

A cavity filter

E7C11 Which of the following is the common name for a filter network which is equivalent to two L networks connected back-to-back with the inductors in series and the capacitors in shunt at the input and output?

Pi

E7C12 Which of the following describes a Pi-L network used for matching a vacuum-tube final amplifier to a 50-ohm unbalanced output?

A Pi network with an additional series inductor on the output

E7C13 What is one advantage of a Pi matching network over an L matching network consisting of a single inductor and a single capacitor?

The Q of Pi networks can be varied depending on the component values chosen

E7C14 Which of these modes is most affected by non-linear phase response in a receiver IF filter?

Digital

E7D01 What is one characteristic of a linear electronic voltage regulator?

The conduction of a control element is varied to maintain a constant output voltage

E7D02 What is one characteristic of a switching electronic voltage regulator?

The control device's duty cycle is controlled to produce a constant average output voltage

E7D03 What device is typically used as a stable reference voltage in a linear voltage regulator?

A Zener diode

E7D04 Which of the following types of linear voltage regulator usually make the most efficient use of the primary power source?

A series regulator

E7D05 Which of the following types of linear voltage regulator places a constant load on the unregulated voltage source?

A shunt regulator

E7D06 What is the purpose of Q1 in the circuit shown in Figure E7-3?

It increases the current-handling capability of the regulator

E7D07 What is the purpose of C2 in the circuit shown in Figure E7-3?

It bypasses hum around D1

E7D08 What type of circuit is shown in Figure E7-3?

Linear voltage regulator

E7D09 What is the purpose of C1 in the circuit shown in Figure E7-3?

It filters the supply voltage

E7D10 What is the purpose of C3 in the circuit shown in Figure E7-3?

It prevents self-oscillation

E7D11 What is the purpose of R1 in the circuit shown in Figure E7-3?

It supplies current to D1

E7D12 What is the purpose of R2 in the circuit shown in Figure E7-3?

It provides a constant minimum load for Q1

E7D13 What is the purpose of D1 in the circuit shown in Figure E7-3?

To provide a voltage reference

E7D14 What is one purpose of a "bleeder" resistor in a conventional (unregulated) power supply?

To improve output voltage regulation

E7D15 What is the purpose of a "step-start" circuit in a high-voltage power supply?

To allow the filter capacitors to charge gradually

E7D16 When several electrolytic filter capacitors are connected in series to increase the operating voltage of a power supply filter circuit, why should resistors be connected across each capacitor?

All of these choices are correct

E7D17 What is the primary reason that a high-frequency inverter type high-voltage power supply can be both less expensive and lighter in weight than a conventional power supply?

The high frequency inverter design uses much smaller transformers and filter components for an equivalent power output

E7E01 Which of the following can be used to generate FM phone emissions?

A reactance modulator on the oscillator

E7E02 What is the function of a reactance modulator?

To produce PM signals by using an electrically variable inductance or capacitance

E7E03 How does an analog phase modulator function?

By varying the tuning of an amplifier tank circuit to produce PM signals

E7E04 What is one way a single-sideband phone signal can be generated?

By using a balanced modulator followed by a filter

E7E05 What circuit is added to an FM transmitter to boost the higher audio frequencies?

A pre-emphasis network

E7E06 Why is de-emphasis commonly used in FM communications receivers?

For compatibility with transmitters using phase modulation

E7E07 What is meant by the term baseband in radio communications?

The frequency components present in the modulating signal

E7E08 What are the principal frequencies that appear at the output of a mixer circuit?

The two input frequencies along with their sum and difference frequencies

E7E09 What occurs when an excessive amount of signal energy reaches a mixer circuit?

Spurious mixer products are generated

E7E10 How does a diode detector function?

By rectification and filtering of RF signals

E7E11 Which of the following types of detector is well suited for demodulating SSB signals?

Product detector

E7E12 What is a frequency discriminator stage in a FM receiver?

A circuit for detecting FM signals

E7E13 Which of the following describes a common means of generating an SSB signal when using digital signal processing?

The quadrature method

E7E14 What is meant by direct conversion when referring to a software defined receiver?

Incoming RF is mixed to "baseband" for analog-to-digital conversion and subsequent processing

E7F01 What is the purpose of a prescaler circuit?

It divides a higher frequency signal so a low-frequency counter can display the input frequency

E7F02 Which of the following would be used to reduce a signal's frequency by a factor of ten?

A prescaler

E7F03 What is the function of a decade counter digital IC?

It produces one output pulse for every ten input pulses

E7F04 What additional circuitry must be added to a 100-kHz crystal-controlled marker generator so as to provide markers at 50 and 25 kHz?

Two flip-flops

E7F05 Which of the following is a technique for providing high stability oscillators needed for microwave transmission and reception?

All of these choices are correct

E7F06 What is one purpose of a marker generator?

To provide a means of calibrating a receiver's frequency settings

E7F07 What determines the accuracy of a frequency counter?

The accuracy of the time base

E7F08 Which of the following is performed by a frequency counter?

Counting the number of input pulses occurring within a specific period of time

E7F09 What is the purpose of a frequency counter?

To provide a digital representation of the frequency of a signal

E7F10 What alternate method of determining frequency, other than by directly counting input pulses, is used by some counters?

Period measurement plus mathematical computation

E7F11 What is an advantage of a period-measuring frequency counter over a direct-count type?

It provides improved resolution of low-frequency signals within a comparable time period

E7G01 What primarily determines the gain and frequency characteristics of an op-amp RC active filter?

The values of capacitors and resistors external to the op-amp

E7G02 What is the effect of ringing in a filter?

Undesired oscillations added to the desired signal

E7G03 Which of the following is an advantage of using an op-amp instead of LC elements in an audio filter?

Op-amps exhibit gain rather than insertion loss

E7G04 Which of the following is a type of capacitor best suited for use in high-stability op-amp RC active filter circuits?

Polystyrene

E7G05 How can unwanted ringing and audio instability be prevented in a multi-section op-amp RC audio filter circuit?

Restrict both gain and Q

E7G06 Which of the following is the most appropriate use of an op-amp active filter?

As an audio filter in a receiver

E7G07 What magnitude of voltage gain can be expected from the circuit in Figure E7-4 when R1 is 10 ohms and RF is 470 ohms?

47

E7G08 How does the gain of an ideal operational amplifier vary with frequency?

It does not vary with frequency

E7G09 What will be the output voltage of the circuit shown in Figure E7-4 if R1 is 1000 ohms, RF is 10,000 ohms, and 0.23 volts dc is applied to the input?

-2.3 volts

E7G10 What absolute voltage gain can be expected from the circuit in Figure E7-4 when R1 is 1800 ohms and RF is 68 kilohms?

38

E7G11 What absolute voltage gain can be expected from the circuit in Figure E7-4 when R1 is 3300 ohms and RF is 47 kilohms?

14

E7G12 What is an integrated circuit operational amplifier?

A high-gain, direct-coupled differential amplifier with very high input and very low output impedance

E7G13 What is meant by the term op-amp input-offset voltage?

The differential input voltage needed to bring the open-loop output voltage to zero

E7G14 What is the typical input impedance of an integrated circuit op-amp?

Very high

E7G15 What is the typical output impedance of an integrated circuit op-amp?

Very low

E7H01 What are three oscillator circuits used in Amateur Radio equipment?

Colpitts, Hartley and Pierce

E7H02 What condition must exist for a circuit to oscillate?

It must have positive feedback with a gain greater than 1

E7H03 How is positive feedback supplied in a Hartley oscillator?

Through a tapped coil

E7H04 How is positive feedback supplied in a Colpitts oscillator?

Through a capacitive divider

E7H05 How is positive feedback supplied in a Pierce oscillator?

Through a quartz crystal

E7H06 Which of the following oscillator circuits are commonly used in VFOs?

Colpitts and Hartley

E7H07 What is a magnetron oscillator?

A UHF or microwave oscillator consisting of a diode vacuum tube with a specially shaped anode, surrounded by an external magnet

E7H08 What is a Gunn diode oscillator?

An oscillator based on the negative resistance properties of properly-doped semiconductors

E7H09 What type of frequency synthesizer circuit uses a phase accumulator, lookup table, digital to analog converter and a low-pass anti-alias filter?

A direct digital synthesizer

E7H10 What information is contained in the lookup table of a direct digital frequency synthesizer?

The amplitude values that represent a sine-wave output

E7H11 What are the major spectral impurity components of direct digital synthesizers?

Spurious signals at discrete frequencies

E7H12 Which of the following is a principal component of a direct digital synthesizer (DDS)?

Phase accumulator

E7H13 What is the capture range of a phase-locked loop circuit?

The frequency range over which the circuit can lock

E7H14 What is a phase-locked loop circuit?

An electronic servo loop consisting of a phase detector, a low-pass filter, a voltage-controlled oscillator, and a stable reference oscillator

E7H15 Which of these functions can be performed by a phase-locked loop?

Frequency synthesis, FM demodulation

E7H16 Why is the short-term stability of the reference oscillator important in the design of a phase locked loop (PLL) frequency synthesizer?

Any phase variations in the reference oscillator signal will produce phase noise in the synthesizer output

E7H17 Why is a phase-locked loop often used as part of a variable frequency synthesizer for receivers and transmitters?

It makes it possible for a VFO to have the same degree of frequency stability as a crystal oscillator

E7H18 What are the major spectral impurity components of phase-locked loop synthesizers?

Phase noise

E8A01 What type of wave is made up of a sine wave plus all of its odd harmonics?

A square wave

E8A02 What type of wave has a rise time significantly faster than its fall time (or vice versa)?

A sawtooth wave

E8A03 What type of wave is made up of sine waves of a given fundamental frequency plus all its harmonics?

A sawtooth wave

E8A04 What is equivalent to the root-mean-square value of an AC voltage?

The DC voltage causing the same amount of heating in a resistor as the corresponding RMS AC voltage

E8A05 What would be the most accurate way of measuring the RMS voltage of a complex waveform?

By measuring the heating effect in a known resistor

E8A06 What is the approximate ratio of PEP-to-average power in a typical single-sideband phone signal?

2.5 to 1

E8A07 What determines the PEP-to-average power ratio of a single-sideband phone signal?

The characteristics of the modulating signal

E8A08 What is the period of a wave?

The time required to complete one cycle

E8A09 What type of waveform is produced by human speech?

Irregular

E8A10 Which of the following is a distinguishing characteristic of a pulse waveform?

Narrow bursts of energy separated by periods of no signal

E8A11 What is one use for a pulse modulated signal?

Digital data transmission

E8A12 What type of information can be conveyed using digital waveforms?

All of these choices are correct

E8A13 What is an advantage of using digital signals instead of analog signals to convey the same information?

Digital signals can be regenerated multiple times without error

E8A14 Which of these methods is commonly used to convert analog signals to digital signals?

Sequential sampling

E8A15 What would the waveform of a stream of digital data bits look like on a conventional oscilloscope?

A series of pulses with varying patterns

E8B01 What is the term for the ratio between the frequency deviation of an RF carrier wave, and the modulating frequency of its corresponding FM-phone signal?

Modulation index

E8B02 How does the modulation index of a phase-modulated emission vary with RF carrier frequency (the modulated frequency)?

It does not depend on the RF carrier frequency

E8B03 What is the modulation index of an FM-phone signal having a maximum frequency deviation of 3000 Hz either side of the carrier frequency, when the modulating frequency is 1000 Hz?

3

E8B04 What is the modulation index of an FM-phone signal having a maximum carrier deviation of plus or minus 6 kHz when modulated with a 2-kHz modulating frequency?

3

E8B05 What is the deviation ratio of an FM-phone signal having a maximum frequency swing of plus-or-minus 5 kHz when the maximum modulation frequency is 3 kHz?

1.67

E8B06 What is the deviation ratio of an FM-phone signal having a maximum frequency swing of plus or minus 7.5 kHz when the maximum modulation frequency is 3.5 kHz?

2.14

E8B07 When using a pulse-width modulation system, why is the transmitter's peak power greater than its average power?

The signal duty cycle is less than 100%

E8B08 What parameter does the modulating signal vary in a pulse-position modulation system?

The time at which each pulse occurs

E8B09 What is meant by deviation ratio?

The ratio of the maximum carrier frequency deviation to the highest audio modulating frequency

E8B10 Which of these methods can be used to combine several separate analog information streams into a single analog radio frequency signal?

Frequency division multiplexing

E8B11 Which of the following describes frequency division multiplexing?

Two or more information streams are merged into a "baseband", which then modulates the transmitter

E8B12 What is digital time division multiplexing?

Two or more signals are arranged to share discrete time slots of a data transmission

E8C01 Which one of the following digital codes consists of elements having unequal length?

Morse code

E8C02 What are some of the differences between the Baudot digital code and ASCII?

Baudot uses five data bits per character, ASCII uses seven or eight; Baudot uses two characters as shift codes, ASCII has no shift code

E8C03 What is one advantage of using the ASCII code for data communications?

It is possible to transmit both upper and lower case text

E8C04 What technique is used to minimize the bandwidth requirements of a PSK31 signal?

Use of sinusoidal data pulses

E8C05 What is the necessary bandwidth of a 13-WPM international Morse code transmission?

Approximately 52 Hz

E8C06 What is the necessary bandwidth of a 170-hertz shift, 300-baud ASCII transmission?

0.5 kHz

E8C07 What is the necessary bandwidth of a 4800-Hz frequency shift, 9600-baud ASCII FM transmission?

15.36 kHz

E8C08 What term describes a wide-bandwidth communications system in which the transmitted carrier frequency varies according to some predetermined sequence?

Spread-spectrum communication

E8C09 Which of these techniques causes a digital signal to appear as wide-band noise to a conventional receiver?

Spread-spectrum

E8C10 What spread-spectrum communications technique alters the center frequency of a conventional carrier many times per second in accordance with a pseudo-random list of channels?

Frequency hopping

E8C11 What spread-spectrum communications technique uses a high speed binary bit stream to shift the phase of an RF carrier?

Direct sequence

E8C12 What is the advantage of including a parity bit with an ASCII character stream?

Some types of errors can be detected

E8C13 What is one advantage of using JT-65 coding?

The ability to decode signals which have a very low signal to noise ratio

E8D01 Which of the following is the easiest voltage amplitude parameter to measure when viewing a pure sine wave signal on an analog oscilloscope?

Peak-to-peak voltage

E8D02 What is the relationship between the peak-to-peak voltage and the peak voltage amplitude of a symmetrical waveform?

2:1

E8D03 What input-amplitude parameter is valuable in evaluating the signal-handling capability of a Class A amplifier?

Peak voltage

E8D04 What is the PEP output of a transmitter that develops a peak voltage of 30 volts into a 50-ohm load?

9 watts

E8D05 If an RMS-reading AC voltmeter reads 65 volts on a sinusoidal waveform, what is the peak-to-peak voltage?

184 volts

E8D06 What is the advantage of using a peak-reading wattmeter to monitor the output of a SSB phone transmitter?

It gives a more accurate display of the PEP output when modulation is present

E8D07 What is an electromagnetic wave?

A wave consisting of an electric field and a magnetic field oscillating at right angles to each other

E8D08 Which of the following best describes electromagnetic waves traveling in free space?

Changing electric and magnetic fields propagate the energy

E8D09 What is meant by circularly polarized electromagnetic waves?

Waves with a rotating electric field

E8D10 What type of meter should be used to monitor the output signal of a voice-modulated single-sideband transmitter to ensure you do not exceed the maximum allowable power?

A peak-reading wattmeter

E8D11 What is the average power dissipated by a 50-ohm resistive load during one complete RF cycle having a peak voltage of 35 volts?

12.2 watts

E8D12 What is the peak voltage of a sinusoidal waveform if an RMS-reading voltmeter reads 34 volts?

48 volts

E8D13 Which of the following is a typical value for the peak voltage at a standard U.S. household electrical outlet?

170 volts

E8D14 Which of the following is a typical value for the peak-to-peak voltage at a standard U.S. household electrical outlet?

340 volts

E8D15 Which of the following is a typical value for the RMS voltage at a standard U.S. household electrical power outlet?

120V AC

E8D16 What is the RMS value of a 340-volt peak-to-peak pure sine wave?

120V AC

E9A01 Which of the following describes an isotropic antenna?

A theoretical antenna used as a reference for antenna gain

E9A02 How much gain does a 1/2-wavelength dipole in free space have compared to an isotropic antenna?

2.15 dB

E9A03 Which of the following antennas has no gain in any direction?

Isotropic antenna

E9A04 Why would one need to know the feed point impedance of an antenna?

To match impedances in order to minimize standing wave ratio on the transmission line

E9A05 Which of the following factors may affect the feed point impedance of an antenna?

Antenna height, conductor length/diameter ratio and location of nearby conductive objects

E9A06 What is included in the total resistance of an antenna system?

Radiation resistance plus ohmic resistance

E9A07 What is a folded dipole antenna?

A dipole constructed from one wavelength of wire forming a very thin loop

E9A08 What is meant by antenna gain?

The ratio relating the radiated signal strength of an antenna in the direction of maximum radiation to that of a reference antenna

E9A09 What is meant by antenna bandwidth?

The frequency range over which an antenna satisfies a performance requirement

E9A10 How is antenna efficiency calculated?

(radiation resistance / total resistance) x 100%

E9A11 Which of the following choices is a way to improve the efficiency of a ground-mounted quarter-wave vertical antenna?

Install a good radial system

E9A12 Which of the following factors determines ground losses for a ground-mounted vertical antenna operating in the 3-30 MHz range?

Soil conductivity

E9A13 How much gain does an antenna have compared to a 1/2-wavelength dipole when it has 6 dB gain over an isotropic antenna?

3.85 dB

E9A14 How much gain does an antenna have compared to a 1/2-wavelength dipole when it has 12 dB gain over an isotropic antenna?

9.85 dB

E9A15 What is meant by the radiation resistance of an antenna?

The value of a resistance that would dissipate the same amount of power as that radiated from an antenna

E9B01 In the antenna radiation pattern shown in Figure E9-1, what is the 3-dB beamwidth?

50 degrees

E9B02 In the antenna radiation pattern shown in Figure E9-1, what is the front-to-back ratio?

18 dB

E9B03 In the antenna radiation pattern shown in Figure E9-1, what is the front-to-side ratio?

14 dB

E9B04 What may occur when a directional antenna is operated at different frequencies within the band for which it was designed?

The gain may change depending on frequency

E9B05 What usually occurs if a Yagi antenna is designed solely for maximum forward gain?

The front-to-back ratio decreases

E9B06 If the boom of a Yagi antenna is lengthened and the elements are properly retuned, what usually occurs?

The gain increases

E9B07 How does the total amount of radiation emitted by a directional gain antenna compare with the total amount of radiation emitted from an isotropic antenna, assuming each is driven by the same amount of power?

They are the same

E9B08 How can the approximate beamwidth in a given plane of a directional antenna be determined?

Note the two points where the signal strength of the antenna is 3 dB less than maximum and compute the angular difference

E9B09 What type of computer program technique is commonly used for modeling antennas?

Method of Moments

E9B10 What is the principle of a Method of Moments analysis?

A wire is modeled as a series of segments, each having a uniform value of current

E9B11 What is a disadvantage of decreasing the number of wire segments in an antenna model below the guideline of 10 segments per half-wavelength?

The computed feed point impedance may be incorrect

E9B12 What is the far-field of an antenna?

The region where the shape of the antenna pattern is independent of distance

E9B13 What does the abbreviation NEC stand for when applied to antenna modeling programs?

Numerical Electromagnetics Code

E9B14 What type of information can be obtained by submitting the details of a proposed new antenna to a modeling program?

All of these choices are correct

E9C01 What is the radiation pattern of two $1/4$ -wavelength vertical antennas spaced $1/2$ -wavelength apart and fed 180 degrees out of phase?

A figure-8 oriented along the axis of the array

E9C02 What is the radiation pattern of two $1/4$ -wavelength vertical antennas spaced $1/4$ -wavelength apart and fed 90 degrees out of phase?

A cardioid

E9C03 What is the radiation pattern of two $1/4$ -wavelength vertical antennas spaced $1/2$ -wavelength apart and fed in phase?

A Figure-8 broadside to the axis of the array

E9C04 Which of the following describes a basic unterminated rhombic antenna?

Bidirectional; four-sides, each side one or more wavelengths long; open at the end opposite the transmission line connection

E9C05 What are the disadvantages of a terminated rhombic antenna for the HF bands?

The antenna requires a large physical area and 4 separate supports

E9C06 What is the effect of a terminating resistor on a rhombic antenna?

It changes the radiation pattern from bidirectional to unidirectional

E9C07 What type of antenna pattern over real ground is shown in Figure E9-2?

Elevation

E9C08 What is the elevation angle of peak response in the antenna radiation pattern shown in Figure E9-2?

7.5 degrees

E9C09 What is the front-to-back ratio of the radiation pattern shown in Figure E9-2?

28 dB

E9C10 How many elevation lobes appear in the forward direction of the antenna radiation pattern shown in Figure E9-2?

4

E9C11 How is the far-field elevation pattern of a vertically polarized antenna affected by being mounted over seawater versus rocky ground?

The low-angle radiation increases

E9C12 When constructing a Beverage antenna, which of the following factors should be included in the design to achieve good performance at the desired frequency?

It should be one or more wavelengths long

E9C13 What is the main effect of placing a vertical antenna over an imperfect ground?

It reduces low-angle radiation

E9D01 How does the gain of an ideal parabolic dish antenna change when the operating frequency is doubled?

Gain increases by 6 dB

E9D02 How can linearly polarized Yagi antennas be used to produce circular polarization?

Arrange two Yagis perpendicular to each other with the driven elements at the same point on the boom and fed 90 degrees out of phase

E9D03 How does the beamwidth of an antenna vary as the gain is increased?

It decreases

E9D04 Why is it desirable for a ground-mounted satellite communications antenna system to be able to move in both azimuth and elevation?

In order to track the satellite as it orbits the Earth

E9D05 Where should a high-Q loading coil be placed to minimize losses in a shortened vertical antenna?

Near the center of the vertical radiator

E9D06 Why should an HF mobile antenna loading coil have a high ratio of reactance to resistance?

To minimize losses

E9D07 What is a disadvantage of using a multiband trapped antenna?

It might radiate harmonics

E9D08 What happens to the bandwidth of an antenna as it is shortened through the use of loading coils?

It is decreased

E9D09 What is an advantage of using top loading in a shortened HF vertical antenna?

Improved radiation efficiency

E9D10 What is the approximate feed point impedance at the center of a two-wire folded dipole antenna?

300 ohms

E9D11 What is the function of a loading coil as used with an HF mobile antenna?

To cancel capacitive reactance

E9D12 What is one advantage of using a trapped antenna?

It may be used for multiband operation

E9D13 What happens to feed point impedance at the base of a fixed-length HF mobile antenna as the frequency of operation is lowered?

The radiation resistance decreases and the capacitive reactance increases

E9D14 Which of the following types of conductor would be best for minimizing losses in a station's RF ground system?

A wide flat copper strap

E9D15 Which of the following would provide the best RF ground for your station?

An electrically-short connection to 3 or 4 interconnected ground rods driven into the Earth

E9E01 What system matches a high-impedance transmission line to a lower impedance antenna by connecting the line to the driven element in two places spaced a fraction of a wavelength each side of element center?

The delta matching system

E9E02 What is the name of an antenna matching system that matches an unbalanced feed line to an antenna by feeding the driven element both at the center of the element and at a fraction of a wavelength to one side of center?

The gamma match

E9E03 What is the name of the matching system that uses a section of transmission line connected in parallel with the feed line at or near the feed point?

The stub match

E9E04 What is the purpose of the series capacitor in a gamma-type antenna matching network?

To cancel the inductive reactance of the matching network

E9E05 How must the driven element in a 3-element Yagi be tuned to use a hairpin matching system?

The driven element reactance must be capacitive

E9E06 What is the equivalent lumped-constant network for a hairpin matching system on a 3-element Yagi?

L network

E9E07 What term best describes the interactions at the load end of a mismatched transmission line?

Reflection coefficient

E9E08 Which of the following measurements is characteristic of a mismatched transmission line?

An SWR greater than 1:1

E9E09 Which of these matching systems is an effective method of connecting a 50-ohm coaxial cable feed line to a grounded tower so it can be used as a vertical antenna?

Gamma match

E9E10 Which of these choices is an effective way to match an antenna with a 100-ohm feed point impedance to a 50-ohm coaxial cable feed line?

Insert a 1/4-wavelength piece of 75-ohm coaxial cable transmission line in series between the antenna terminals and the 50-ohm feed cable

E9E11 What is an effective way of matching a feed line to a VHF or UHF antenna when the impedances of both the antenna and feed line are unknown?

Use the universal stub matching technique

E9E12 What is the primary purpose of a phasing line when used with an antenna having multiple driven elements?

It ensures that each driven element operates in concert with the others to create the desired antenna pattern

E9E13 What is the purpose of a Wilkinson divider?

It divides power equally among multiple loads while preventing changes in one load from disturbing power flow to the others

E9F01 What is the velocity factor of a transmission line?

The velocity of the wave in the transmission line divided by the velocity of light in a vacuum

E9F02 Which of the following determines the velocity factor of a transmission line?

Dielectric materials used in the line

E9F03 Why is the physical length of a coaxial cable transmission line shorter than its electrical length?

Electrical signals move more slowly in a coaxial cable than in air

E9F04 What is the typical velocity factor for a coaxial cable with solid polyethylene dielectric?

0.66

E9F05 What is the approximate physical length of a solid polyethylene dielectric coaxial transmission line that is electrically one-quarter wavelength long at 14.1 MHz?

3.5 meters

E9F06 What is the approximate physical length of an air-insulated, parallel conductor transmission line that is electrically one-half wavelength long at 14.10 MHz?

10 meters

E9F07 How does ladder line compare to small-diameter coaxial cable such as RG-58 at 50 MHz?

Lower loss

E9F08 What is the term for the ratio of the actual speed at which a signal travels through a transmission line to the speed of light in a vacuum?

Velocity factor

E9F09 What is the approximate physical length of a solid polyethylene dielectric coaxial transmission line that is electrically one-quarter wavelength long at 7.2 MHz?

6.9 meters

E9F10 What impedance does a $1/8$ -wavelength transmission line present to a generator when the line is shorted at the far end?

An inductive reactance

E9F11 What impedance does a $1/8$ -wavelength transmission line present to a generator when the line is open at the far end?

A capacitive reactance

E9F12 What impedance does a $1/4$ -wavelength transmission line present to a generator when the line is open at the far end?

Very low impedance

E9F13 What impedance does a $1/4$ -wavelength transmission line present to a generator when the line is shorted at the far end?

Very high impedance

E9F14 What impedance does a $1/2$ -wavelength transmission line present to a generator when the line is shorted at the far end?

Very low impedance

E9F15 What impedance does a $1/2$ -wavelength transmission line present to a generator when the line is open at the far end?

Very high impedance

E9F16 Which of the following is a significant difference between foam-dielectric coaxial cable and solid-dielectric cable, assuming all other parameters are the same?

All of these choices are correct

E9G01 Which of the following can be calculated using a Smith chart?

Impedance along transmission lines

E9G02 What type of coordinate system is used in a Smith chart?

Resistance circles and reactance arcs

E9G03 Which of the following is often determined using a Smith chart?

Impedance and SWR values in transmission lines

E9G04 What are the two families of circles and arcs that make up a Smith chart?

Resistance and reactance

E9G05 What type of chart is shown in Figure E9-3?

Smith chart

E9G06 On the Smith chart shown in Figure E9-3, what is the name for the large outer circle on which the reactance arcs terminate?

Reactance axis

E9G07 On the Smith chart shown in Figure E9-3, what is the only straight line shown?

The resistance axis

E9G08 What is the process of normalization with regard to a Smith chart?

Reassigning impedance values with regard to the prime center

E9G09 What third family of circles is often added to a Smith chart during the process of solving problems?

Standing-wave ratio circles

E9G10 What do the arcs on a Smith chart represent?

Points with constant reactance

E9G11 How are the wavelength scales on a Smith chart calibrated?

In fractions of transmission line electrical wavelength

E9H01 What is the effective radiated power relative to a dipole of a repeater station with 150 watts transmitter power output, 2-dB feed line loss, 2.2-dB duplexer loss and 7-dBd antenna gain?

286 watts

E9H02 What is the effective radiated power relative to a dipole of a repeater station with 200 watts transmitter power output, 4-dB feed line loss, 3.2-dB duplexer loss, 0.8-dB circulator loss and 10-dBd antenna gain?

317 watts

E9H03 What is the effective isotropic radiated power of a repeater station with 200 watts transmitter power output, 2-dB feed line loss, 2.8-dB duplexer loss, 1.2-dB circulator loss and 7-dBi antenna gain?

252 watts

E9H04 What term describes station output, including the transmitter, antenna and everything in between, when considering transmitter power and system gains and losses?

Effective radiated power

E9H05 What is the main drawback of a wire-loop antenna for direction finding?

It has a bidirectional pattern

E9H06 What is the triangulation method of direction finding?

Antenna headings from several different receiving locations are used to locate the signal source

E9H07 Why is it advisable to use an RF attenuator on a receiver being used for direction finding?

It prevents receiver overload which could make it difficult to determine peaks or nulls

E9H08 What is the function of a sense antenna?

It modifies the pattern of a DF antenna array to provide a null in one direction

E9H09 Which of the following describes the construction of a receiving loop antenna?

One or more turns of wire wound in the shape of a large open coil

E9H10 How can the output voltage of a multi-turn receiving loop antenna be increased?

By increasing either the number of wire turns in the loop or the area of the loop structure or both

E9H11 What characteristic of a cardioid-pattern antenna is useful for direction finding?

A very sharp single null

E9H12 What is an advantage of using a shielded loop antenna for direction finding?

It is electro-statically balanced against ground, giving better nulls

EOA01 What, if any, are the differences between the radiation produced by radioactive materials and the electromagnetic energy radiated by an antenna?

Radioactive materials emit ionizing radiation, while RF signals have less energy and can only cause heating

E0A02 When evaluating RF exposure levels from your station at a neighbor's home, what must you do?

Make sure signals from your station are less than the uncontrolled MPE limits

E0A03 Which of the following would be a practical way to estimate whether the RF fields produced by an amateur radio station are within permissible MPE limits?

Use an antenna modeling program to calculate field strength at accessible locations

E0A04 When evaluating a site with multiple transmitters operating at the same time, the operators and licensees of which transmitters are responsible for mitigating over-exposure situations?

Each transmitter that produces 5% or more of its MPE exposure limit at accessible locations

E0A05 What is one of the potential hazards of using microwaves in the amateur radio bands?

The high gain antennas commonly used can result in high exposure levels

E0A06 Why are there separate electric (E) and magnetic (H) field MPE limits?

All of these choices are correct

E0A07 How may dangerous levels of carbon monoxide from an emergency generator be detected?

Only with a carbon monoxide detector

E0A08 What does SAR measure?

The rate at which RF energy is absorbed by the body

E0A09 Which insulating material commonly used as a thermal conductor for some types of electronic devices is extremely toxic if broken or crushed and the particles are accidentally inhaled?

Beryllium Oxide

E0A10 What material found in some electronic components such as high-voltage capacitors and transformers is considered toxic?

Polychlorinated biphenyls

E0A11 Which of the following injuries can result from using high-power UHF or microwave transmitters?

Localized heating of the body from RF exposure in excess of the MPE limits

Figure E6-2

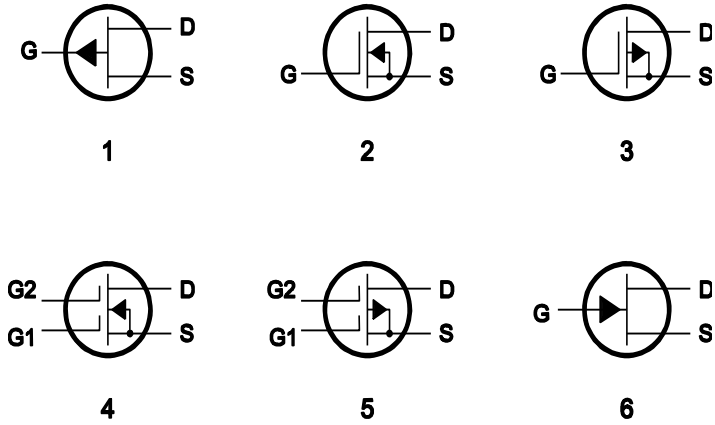

Figure E6-3

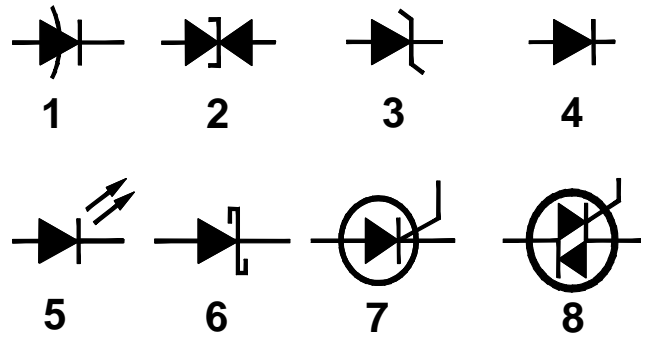

Figure E6-5

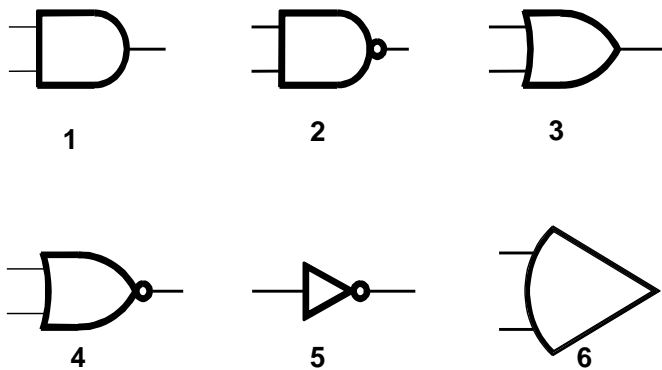

Figure E7-1

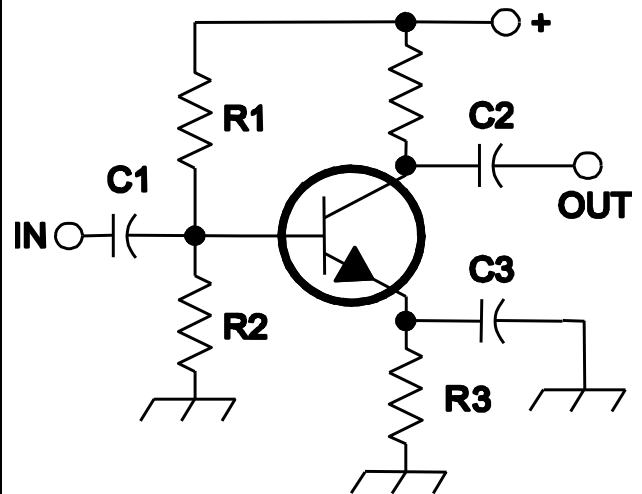

Figure E7-2

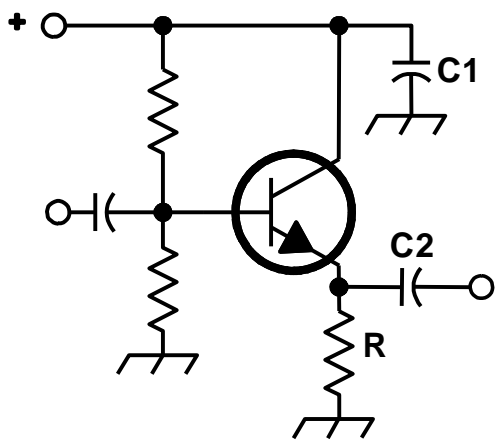

Figure E7-3

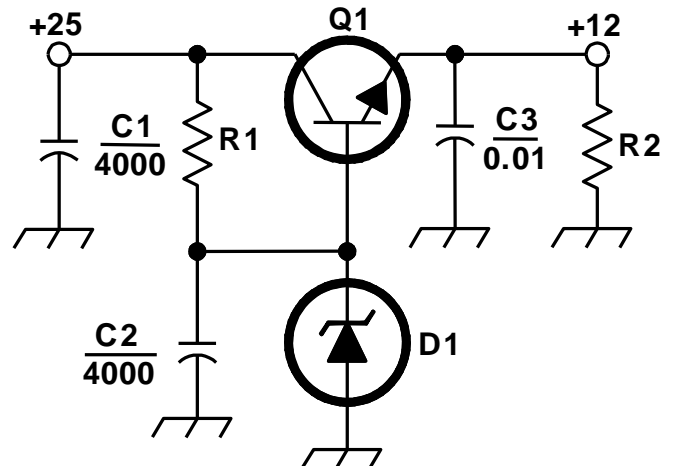

Figure E7-4

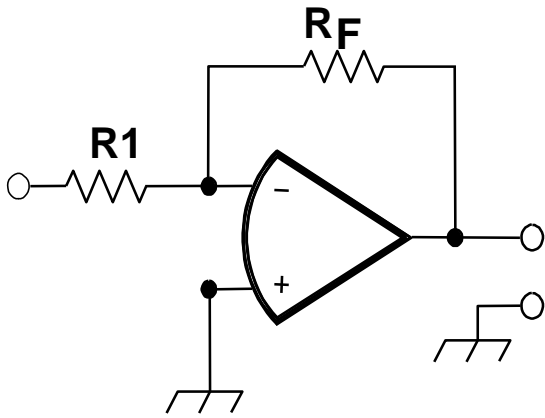

Figure E9-1

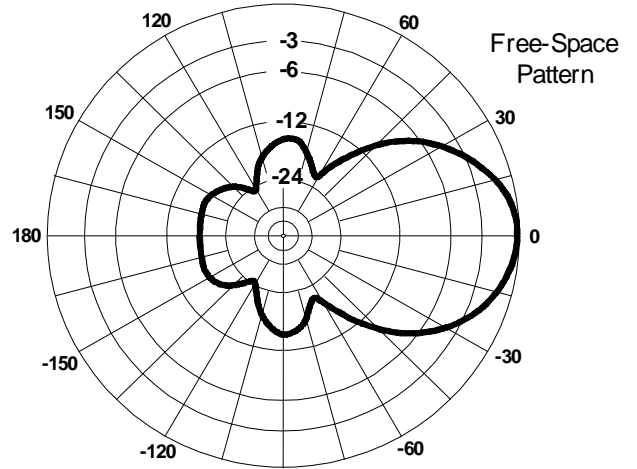

Figure E9-2

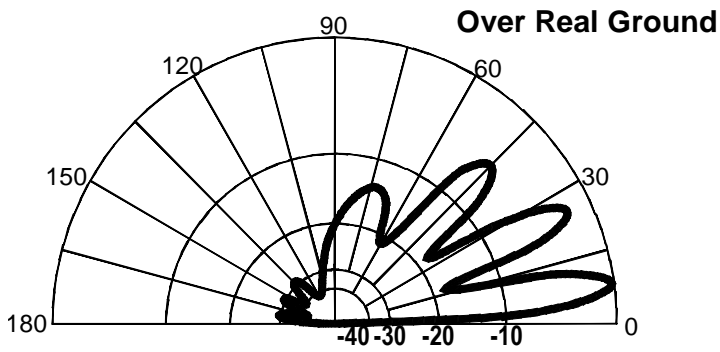

Figure E9-3

